

SAFE-T-PROOF™ Earthquake Fastener STP-MP-202/203: INSTALLATION INSTRUCTIONS

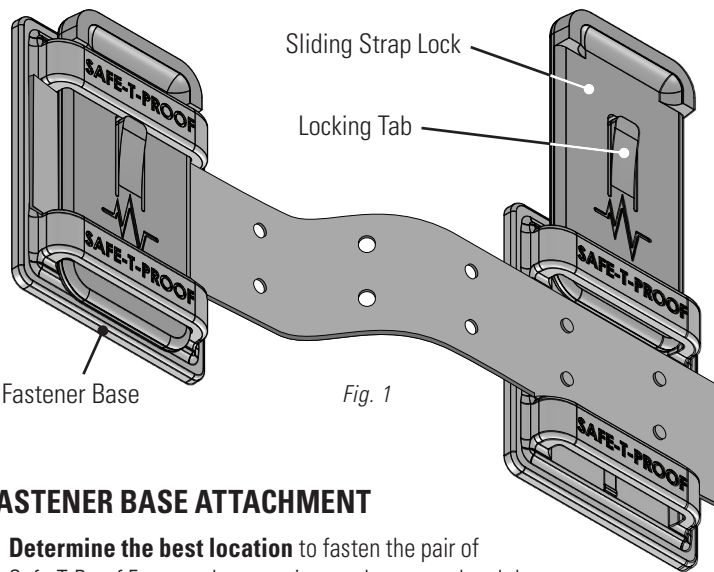

Fig. 1

FASTENER BASE ATTACHMENT

1. **Determine the best location** to fasten the pair of Safe-T-Proof Fastener bases to item to be secured and the surfaces to which they will be secured.
2. **Clean the selected surfaces** – on item to be fastened and on the surface where it will be secured – **with isopropyl alcohol and wipe dry**. This is very important in creating the best adhesion. Do not attach to surfaces that can peel off. Do not use other cleaning agents which may leave residues that can prevent the adhesive from fully attaching to the surface.
3. **Remove protective red sheet** from the adhesive pad on one fastener base. Hold the fastener base by its edges when handling. ***Do not touch the adhesive surface once the protective sheet is removed.***
4. **Carefully place the fastener in position** (at the location determined in Step 1 and cleaned in Step 2) and attach the exposed adhesive. Remember, once the adhesive makes contact, that's where it's going to be.
5. **Press hard on the base** once attached in place to ensure good contact between the adhesive and surfaces.
6. **Repeat Steps 3 through 5** for the other fastener base. It is recommended that you **do not pull the strap taut before affixing any fastener base**. ***Leave some slack in the strap so that the bond can set more thoroughly.***
7. **Let the fastener sit undisturbed for 72 hours** to ensure a proper bond.

STRAP ADJUSTMENT & RELEASE

Releasing the Strap: Press down the locking tab (shown in Fig. 1, above) and slide out the strap lock. The strap is instantly free to remove or adjust.

Adjusting the Strap: If simply adjusting strap length, lift and slip the strap into its new pins position and slide the strap lock back in place until the locking tab snaps to its lock position.

APPLICATION TECHNIQUES for the Safe-T-Proof Fastener's 3M VHB Adhesive Tapes:

CLEANING: Most substrates are best prepared by cleaning with a 70% mixture of isopropyl alcohol (IPA*) and water prior to applying the adhesive

Exceptions to the general procedure that may require additional surface preparation include:

- **Heavy Oils:** A degreaser or solvent-based cleaner may be required to remove heavy oil or grease from a surface and should be followed by cleaning with IPA/water.
- **Abrasion:** Abrading a surface, followed by cleaning with IPA/water, can remove heavy dirt or oxidation and can increase surface area to improve adhesion.
- **Adhesion Promoters:** Priming a surface can significantly improve initial and ultimate adhesion to many materials such as plastics and paints.

FASTENING TO TABLETOP/COUNTERTOP

Fig. 2

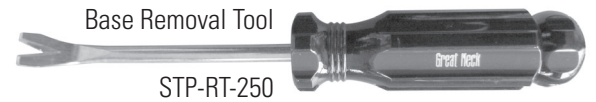
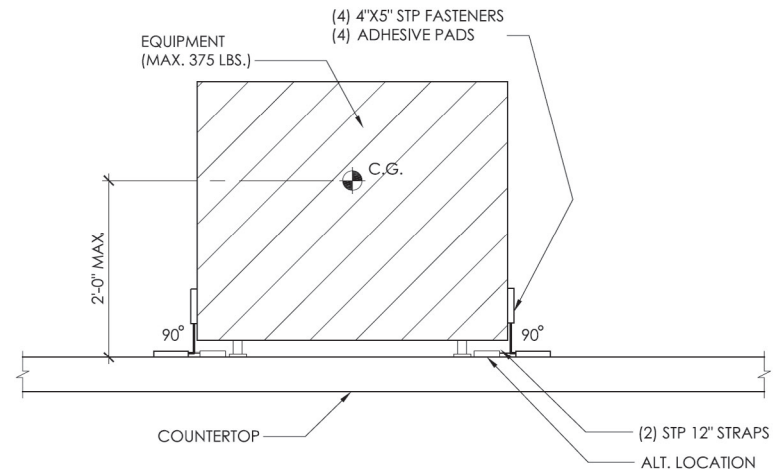

BASE REMOVAL

Removing Safe-T-Proof Fastener From Surfaces

1. Spray denatured alcohol around perimeter of the fastener base to be removed.
2. Using a prying tool, carefully and slowly pry off the adhesive from one corner of the fastener base (Fig. 3). Protect the surface by placing a piece of wood, plastic or metal under the prying tool you will use.
3. Remove the adhesive by pulling it back on itself (Fig. 4).
4. Once the adhesive is removed, it can be replaced and the Safe-T-Proof Fastener can be reused.

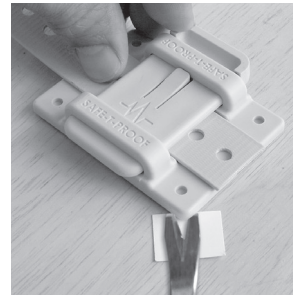

Fig. 3

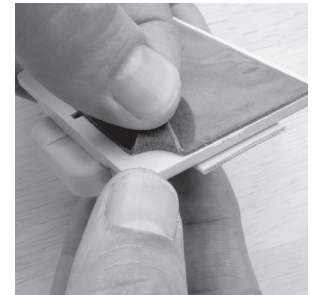

Fig. 4

FASTENING TO WALL AND/OR FLOOR: See reverse side for instructions on fastening to wall and/or floor.

• **Porous Surfaces:** Most porous and fibered materials such as wood, particleboard, concrete, etc. need to be sealed to provide a unified surface.

• **Unique Materials:** Special surface preparation may be needed for glass and glass-like materials, copper and copper containing metals, and plastics or rubber that contain components that migrate (e.g. plasticizers).

• **Rough-Textured Surfaces:** Equipment surfaces that have a slightly rough texture (as is common with many refrigeration units) should be treated with an emery cloth before putting on the adhesive.

Scrub the area the fastener will be attached to with the emery cloth. Clean the surface once with the alcohol wipe to remove the particle that will be on the unit's surface after scrubbing. Allow to dry, and then clean a 2nd time with an additional wipe. Once the surface is dry, go ahead and affix the peel-and-stick fastener.

FASTENING TO WALL (1) : USING STRUTS

Fig. 5

SIDE VIEW

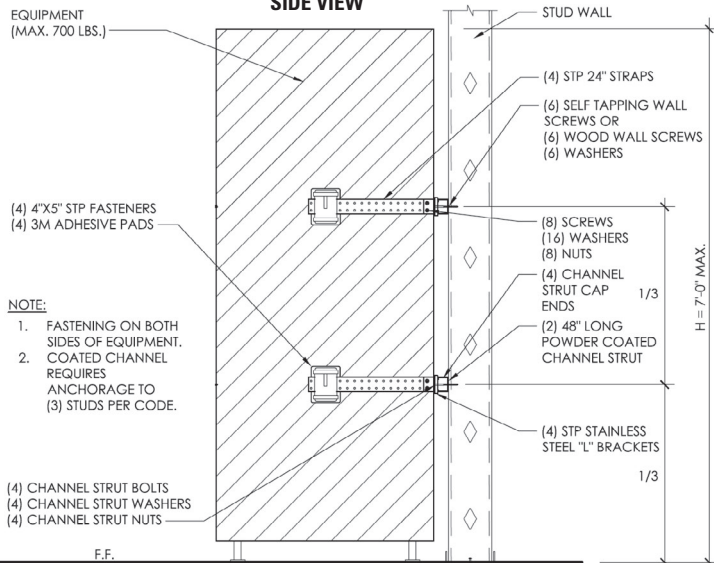

LARGE FREE STANDING EQUIPMENT (FREEZERS, REFRIGERATORS AND FUME HOODS) 7'-0" HIGH MAX. WALL BRACE - SECTION (MAX. 700 LBS.)

Fig. 6

FRONT VIEW

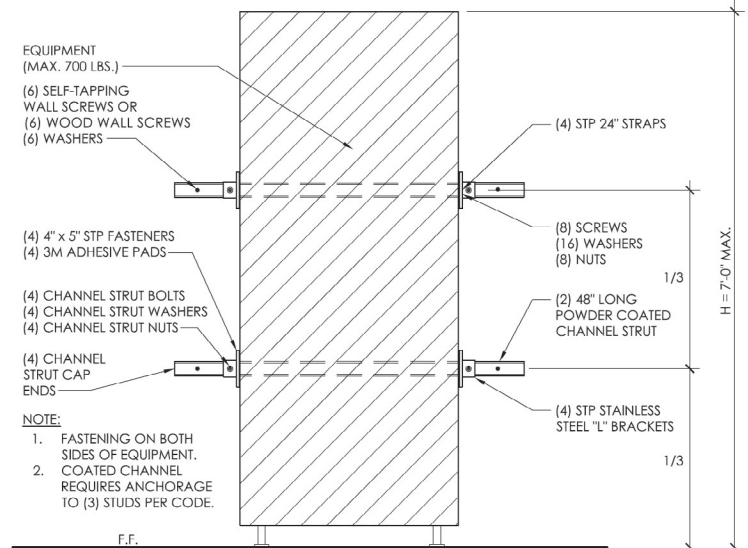

LARGE FREE STANDING EQUIPMENT (FREEZERS, REFRIGERATORS AND FUME HOODS) 7'-0" HIGH MAX. WALL BRACE - ELEVATION (MAX. 700 LBS.)

FASTENING TO WALL (2) : NO DRILLING

Fig. 7

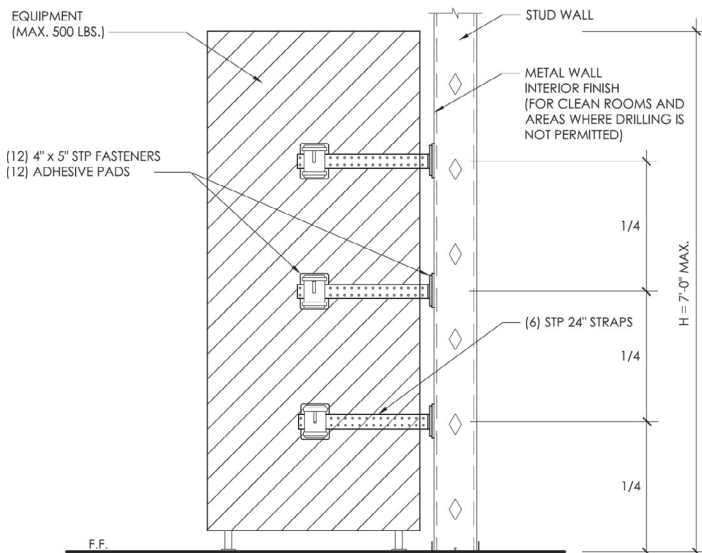

LARGE FREE STANDING EQUIPMENT 7'-0" HIGH MAX. METAL WALL BRACE - SECTION (MAX. 500 LBS.)

FASTENING TO FLOOR (3)

Fig. 8

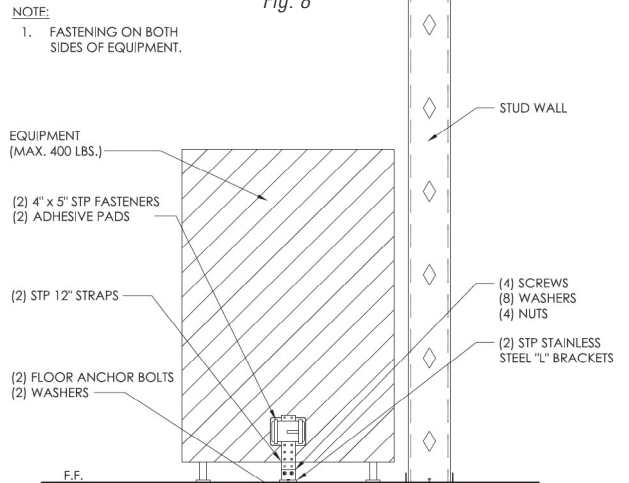

LARGE FREE STANDING EQUIPMENT UNDER 48" TALL (MAX. 400 LBS.)

FASTENING TO WALL & FLOOR: Where appropriate, a combination of wall and floor fastening can increase the anchorage strength for the item being secured.

NOTE: Details in Figure 2 (reverse page) and Figures 5 through 8 (above) only show suggested fastener locations based on common situations. Your Engineer of Record should design and approve your anchorage based on site-specific conditions and applicable codes. For wall fastening, your Engineer of Record should also verify adequate attachment of top of wall to structure above.

WARRANTY AND DISCLAIMER: The SAFE-T-PROOF Earthquake Fastening System is sold under this warranty and disclaimer:

WARRANTY: Manufacturer warrants all parts to be in good working condition for a period of One Year providing maintenance and installation was done properly per the installation instructions.

DISCLAIMER: The user shall determine the suitability of the product for the intended use and shall assume all risk and liability in connection therewith; this will include all items sold or distributed by Safe-T-Proof

(STP). User is required to read all instructions and follow the manufacturer's guidelines. STP cannot accept any responsibility for bodily injuries and/or property damage that may occur during the use of its products. In addition, STP cannot be responsible for any injuries or damage that result from a natural disaster or any act of God. STP accepts no responsibility for improper installation of its products.

SAFE-T-PROOF™

Distributed by: www.safe-t-proof.com

Patent# 8,740,172 License# 807773

For more information on preparedness products and services, visit our website at www.safe-t-proof.com or call us toll-free at **800-377-8888**